

8401 Rain Train® Turf Traveler

Parts List & Operating Instructions – Series E/G/H

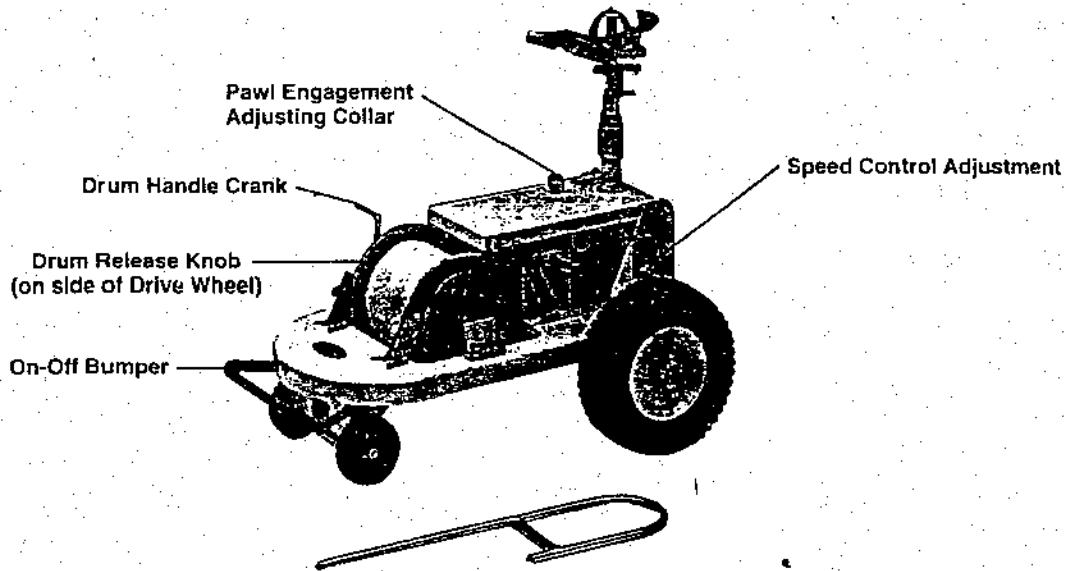

Operating Instructions Rain Train 400 Series "E", "G", "H"

To Set:

- (1) Determine the starting and stopping locations of the Rain Train such that the cable will lay in a straight line along the required travel path for the coverage desired. Be sure that the hose length will reach to both locations and that there are no obstacles to interfere with the required movement of the hose. The maximum travel distance is obtainable when the water supply outlet is near the center of the length of area to be sprinkled.
- (2) Connect hose to water supply and lay it out to the travel path and then along the side of the travel path back to the starting location of the Rain Train.
- (3) Place the Rain Train in the starting location and connect to end of hose.
- (4) Push in on the "ON-OFF Bumper" to close the shut-off valve.
- (5) Pull out on the "Drum Release Knob" (located on the right side of the cable drum) and turn slightly to hold release.
- (6) Unwind the cable from the drum and lay cable along the travel path by walking with the cable tow handle to the stopping location. Be sure the stopping location is not beyond the point that the hose length will reach.
- (7) Put the long end of the stake through the ring end of the cable tow handle and push the stake into the ground to the depth of the foot bar on the stake. The short end of the stake should be toward the direction of pull. See stake instructions on page 4.

Continued on next page.

Cleaning:

Each unit is equipped with two filter screens. One is located in the rear hose nut and the other on the right side of the shut-off valve where the outlet to the tripping valve is located. These screens should be cleaned of debris periodically. If the Rain Train loses driving power, remove the stem from the "Speed Control Adjustment" and flush water through the opening. If the sprinkler pressure drops, check for debris plugging the sprinkler nozzle.

Draining:

To prevent damage to the motor and valve mechanism due to freezing or damage to piston cup and diaphragm during storage, drain the water from the unit by completely opening the speed control adjustment and by opening the shut-off valve by pulling forward on the bumper. Then tip up the front end of the Rain Train to allow the water to drain from the hose coupling.

Cable:

Should the cable be accidentally cut or broken, tie the ends in a square knot and hold a lighted match to the cable ends until material is melted sufficiently to prevent unraveling. Be sure the cable is through the "Cable Guide" under the frame before the cable is tied.

Service:

When contacting your dealer regarding service problems, refer to the Serial No. which is stamped on the name plate of your Rain Train.

How To Select Rain Train Performance

Coverage Length:

The Rain Train has ample power to pull up to 200 ft. of 1" or 1 1/4" nylon reinforced plastic hose full of water on turf making total travel distances up to 400 ft. possible from each water supply outlet. The total length sprinkled is further extended by the coverage of the sprinkler beyond the starting and stopping locations.

Coverage Width:

Either part or full circle NELSON sprinkler within a general capacity range of 3 to 30 g.p.m. and coverage range of 5 to 150 ft. can be operated from the RAIN TRAIN. Refer to the performance charts on NELSON sprinklers for full information on available models, nozzle sizes, capacity and coverages.

Pressure:

To obtain the recommended working pressure as shown by the NELSON sprinkler performance charts, allow for the pressure loss due to friction in all water supply piping and the hose. Use the minimum length of hose that will reach the desired travel distance to reduce the pressure loss.

Spacing:

The spacing between settings of the RAIN TRAIN should be in accordance with the spacing recommendations of NELSON sprinklers. Spacing should not be over 75% of the sprinkler diameter of coverage, without wind. Generally, closer spacing will give better aggregate distribution.

Water Applied:

The total application of water on an area, for a given sprinkler capacity and coverage, is determined by the rate at which the RAIN TRAIN travels across the area. The travel rate can be set within a range of 5 to over 60 ft. per hour. Average Application in Inches equals:

Sprinkler Discharge in G.P.M. X 96.3

Coverage Width in Ft. X Travel Rate in Ft. per Hour

Rain Train Performance

1641 Impact Head				Minimum Pressure To Unit PSI	Sprinkler Capacity GPM	Radius Feet	Spacing Between Travel Lanes	Hose Size	Pressure Loss 200' Coupled Hose PSI	Required Pressure At Hose Inlet PSI	Inches Applied at Stated Travel Speed				
Drive Nozzle		Spreader Nozzle									5'/Hr	10'/Hr	20'/Hr	40'/Hr	60'/Hr
Model	Size	Model	Size												
7516	1/4"			40	11.5	55	75	1"	8	48	2.97	1.48	0.74	0.37	0.25
7516	1/4"	7308	1/8"	40	16.0	55	75	1"	15	55	4.13	2.06	1.03	0.52	0.34
7520	5/16"			50	20.0	63	85	1"	25	75	4.51	2.25	1.13	0.56	0.38
7520	5/16"	7308	1/8"	50	24.6	65	88	1 1/4"	12	62	5.37	2.69	1.34	0.67	0.45
7524	3/8"	7308	1/8"	50	32.7	70	95	1 1/4"	19	69	6.63	3.32	1.66	0.83	0.55

Shaded area indicates gallonage, spacing, and pressure requirements for traveler using Nelson 1641 impact head with standard 1/4" drive nozzle and 200' of 1" hose.

To Start Operation:

- (1) Turn on the water at the hose supply outlet.
- (2) Turn the "Drum Release Knob" to engage pin into the drive wheel.
- (3) Turn the "Drum Hand Crank" until lock plunger engages in the drum.
- (4) Rewind any slack cable onto the drum with the "Drum Hand Crank".
- (5) Hold the sprinkler arm and stand aside of the discharge stream.
- (6) Turn on by pulling out the "ON-OFF" Bumper.

To Stop Operation:

- (1) The Rain Train is automatically shut off at the end of travel by the stake depressing the "ON-OFF Bumper" to close the valve.
- (2) To manually stop at any time, push in on the "ON-OFF Bumper".

Adjustments

Travel Rate:

Turn the "Speed Control Valve" (#26871) (located to the left side of the shut-off valve) out (counterclockwise) to increase speed, and in (clockwise) to decrease speed.

Drum Friction:

If the drum turns too freely, allowing the cable to slack as it is payed from the drum, tighten the "Drum Friction-Adjusting Screw" (#25604) to increase the spring force on the friction plunger against the drum.

Pawl Engagement:

The "Pawl Engagement Adjusting Collars" (#49271) located on the control shaft (#26724) determine the travel distance of the driving pawls. This is factory set to engage three notches and will seldom need adjustment. If the pawls become worn and an adjustment is needed, simply loosen the set screw and position the adjusting collars such that the pawls will properly engage three teeth per cycle. Be sure the lower adjusting collar is positioned high enough on the control shaft so that as the lid is returned to horizontal position it contacts the adjusting collar thus causing the valve to trip just before the lid comes to rest against the upper diaphragm support (#25894).

If the bottom collar is moved the top adjusting collar must also be adjusted. While the unit is operating under load (pressure with hand can be applied to crank handle of the cable drum) check for engagement of the pawls (#25441) so that they engage not more than three teeth on the drive wheels (#25571 and #25581).

The top collar must not allow the lid to raise higher than to allow the diaphragm to be exposed more than 1/4" to 1/2" above upper diaphragm support (#25894) edge and piston cup (#25484), when viewed from the front of the unit and with the diaphragm completely filled. If it is allowed to go higher the diaphragm may rupture prematurely. Even if the pawls will not engage three teeth on the drive wheels do not allow the lid to go higher than stated above.

How to Care for Your Rain Train

Lubrication:

For increased life of the unit, following locations on the unit should be lubricated periodically with a good grade oil.

Valve Stem (#27160) where it protrudes from the valve body (tripping) (#27101).

Front Lid axle (#26774) on pawls (#25441) (both sides).

Rear Lid axle (#26794) at lid bracket (both sides).

Linkage at all pin connections. Lock plunger (#26274) on drum.

Shut-Off valve link (#26684) at its pivot points.

Drum axle (#25564) at spacers (#25824) on each side.

Pin (#26994) on anti-reverse bracket (#25794) (two on each side.)

Front Wheel (#25685) at bushing. (both sides).

Rear Wheel (#25715) at rear axle bolt (#25724) (both sides).

The following location should be grease lubricated periodically with a good grade water resistant grease.

The bumper (#26674) at the cam screw (#41684) (both sides).

NOTE: No grease or oil should be used on sprinkler head bearing.

Typical Rain Train Layout

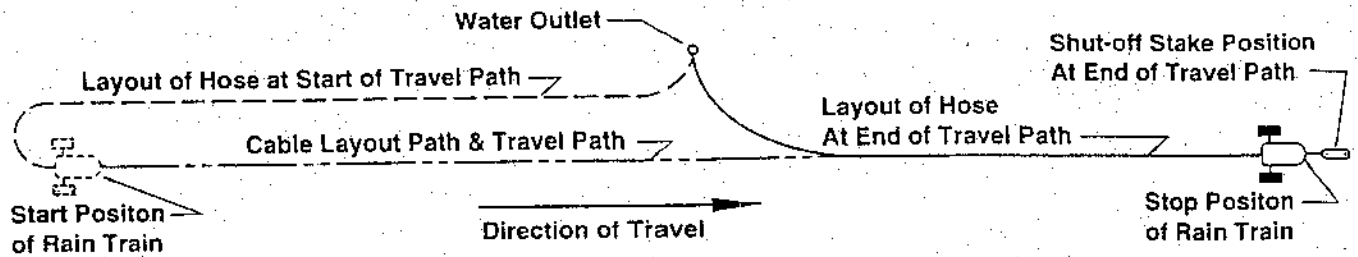

Rain Train Staking Instructions

To Set:

After the cable has been layed along the travel path and the stopping location has been determined, place the long end of the stake through the ring on the tow handle. Position the stake so that the short end is directed toward the direction of pull and place the cable to either side of the short end. Then push the stake into the ground to the depth of the foot bar - making sure the short end is also in the ground.

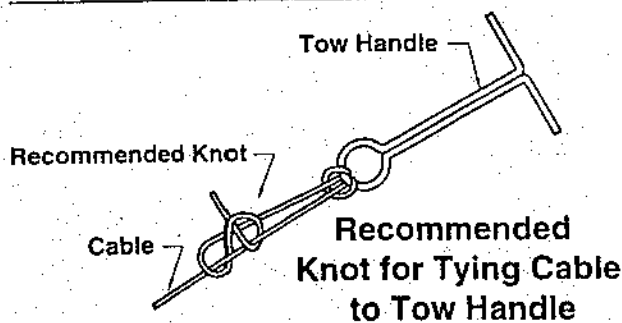
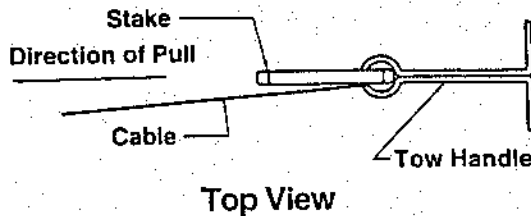
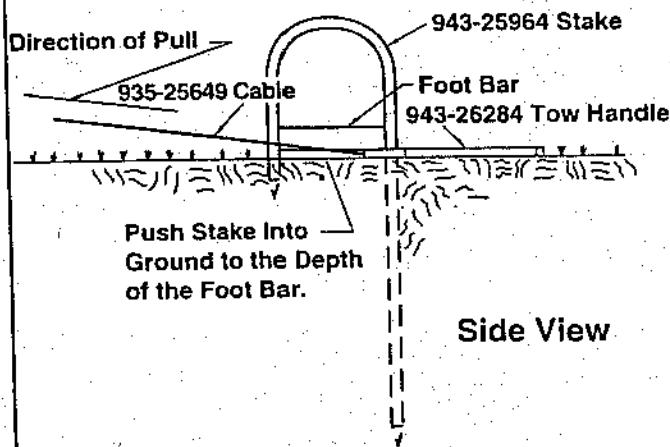

To Remove:

After the unit has struck the stake and shut-off, pull upward on the stake until the short end is entirely out of the ground. Then turn the stake in the direction away from the cable until it is free from the bumper. Now place one foot on the tow handle and pull the stake completely out of the ground.

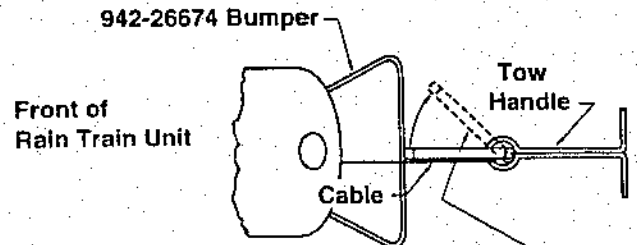
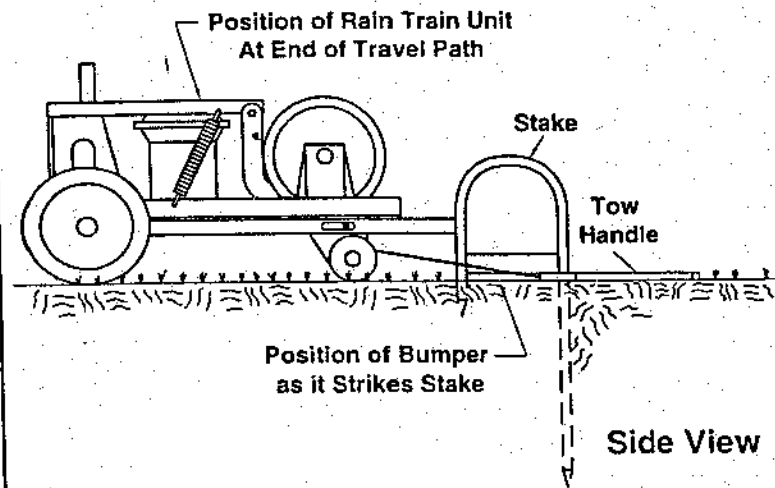

Pull upward on stake until short end is completely out of ground. Then turn stake in direction away from cable until it is free from bumper. Then remove stake from ground.

Top View

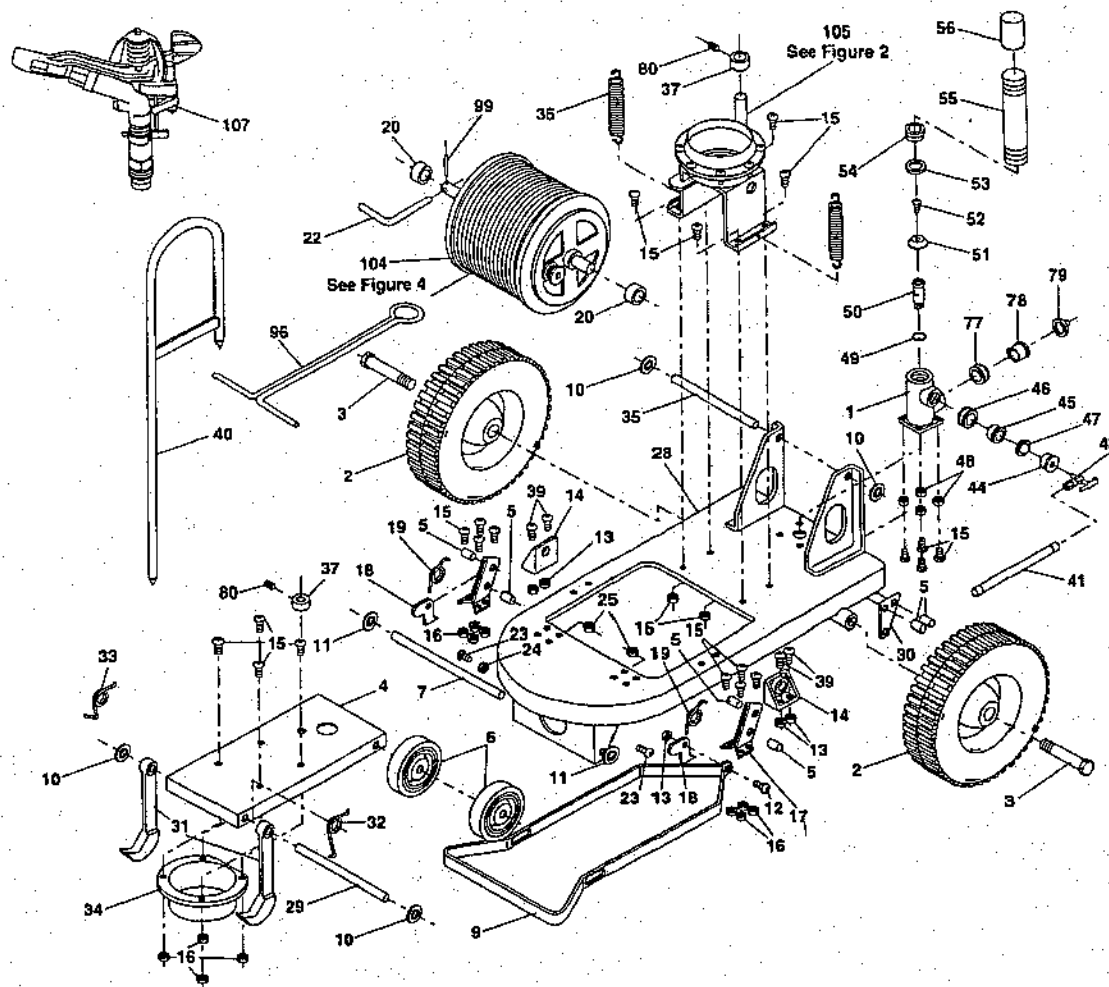

Item No.	Description	Part No.	Qty	Item No.	Description	Part No.	Qty
1	Shut-Off Valve Body	934-27131	1	35	Lid Axle (Rear)	941-26794	1
2	Rear Wheel	935-25715	2	36	Lid Return Spring	935-25904	2
3	Rear Axle Bolt	931-25724	2	37	Adjusting Collar	900-49271	2
4	Lid	800-51410	1	39	Screw	945-27144	4
5	Roll Pin	935-26994	6	40	Stake	943-25964	1
6	Front Wheel	950-25685	2	41	Hose Assembly	480-49075	1
7	Axle (Front Wheel)	941-26784	1	43	Speed Control	935-26871	1
9	Bumper	800-26674	1	44	Male End	911-27061	1
10	Pushnut	945-26884	2	45	Shank	911-40441	1
11	Pushnut	945-43284	2	46	K-Nut	900-37110	1
12	Bolt	945-26144	1	47	Filter Washer	935-27239	1
13	Locknut	945-26044	5	48	Lock Washer	935-26914	4
14	Drum Support Bracket	942-25834	2	49	O-Ring	934-20825	1
15	Screw	945-25464	16	50	Valve Stem	931-26751	1
16	Nut	945-25474	12	51	Stem Cap	931-26761	1
17	Anti-Reverse Bracket	942-25794	2	52	Retainer Screw	935-30314	4
18	Anti-Reverse Dog	942-25814	2	53	Washer	934-26855	1
19	Dog Spring	935-26174	2	54	Washer Retainer	911-27051	1
20	Drive Wheel Spacer	941-25824	2	55	Riser	800-51408	1
22	Crank	942-25844	1	56	Riser Coupling	800-51409	1
23	Cam Screw	935-41684	2	77	Nut	911-00611	1
24	Washer	979-26832	2	78	Valve Shank	911-25411	1
25	Locknut	935-26964	2	79	1" Filter Washer	935-26069	1
28	Frame	800-51407	1	80	Set Screw	900-49272	2
29	Lid Axle (Front)	941-26774	1	96	Tow Handle	943-26284	1
30	Shut-Off Valve Link	942-26684	1	99	Pin	945-26244	1
31	Pawls	934-25441	2	104	Drum and Cable Assembly	480-25510	1
32	Pawl Spring (Left)	935-26154	1	105	Diaphragm Support		
33	Pawl Spring (Right)	935-26164	1		Bracket Assembly	850-27240	1
34	Piston Cup	942-25484	1	107	Model 1641 Impact	1641	1

